

Fairview Europe Ltd

Unit 7, Robins Drive
Castlefield Industrial Estate
Bridgewater
Somerset TA6 4DL

Tel: 01278 428 245

e-mail: sales@valcan.co.uk

website: www.valcan.co.uk



Agrément Certificate

20/5824

Product Sheet 1

FAIRVIEW CLADDING PANELS

VITRADUAL

This Agrément Certificate Product Sheet⁽¹⁾ relates to VitraDual cladding panels, flat aluminium cladding systems, for use in an open-jointed, back ventilated and drained rainscreen cladding system on the external timber- and steel-frame walls of new and existing commercial and residential buildings.

(1) Hereinafter referred to as 'Certificate'.

CERTIFICATION INCLUDES:

- factors relating to compliance with Building Regulations where applicable
- factors relating to additional non-regulatory information where applicable
- independently verified technical specification
- assessment criteria and technical investigations
- design considerations
- installation guidance
- regular surveillance of production
- formal three-yearly review.

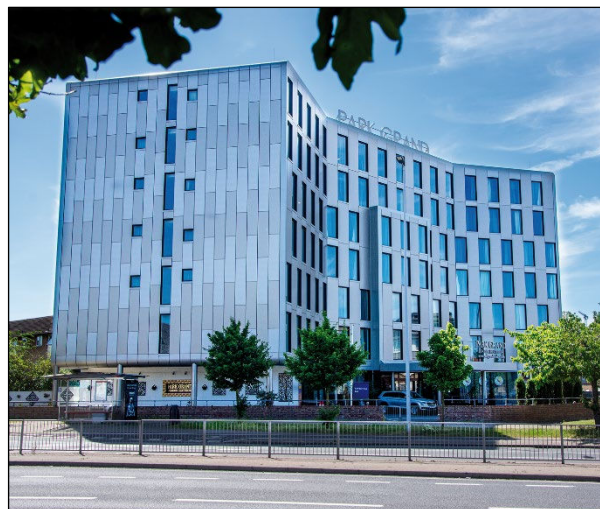

KEY FACTORS ASSESSED

Strength and stability — the panels, when incorporated in a suitably designed cladding system, can safely resist the wind and impact actions normally encountered in the UK (see section 6).

Behaviour in relation to fire — the panel has an A1 reaction to fire classification to BS EN 13501-1 : 2018 (see section 7).

Air and water penetration — the vertical and horizontal joints between the panels will minimise water entering the cavity. Any water collecting in the cavity will be removed by drainage and ventilation (see section 8).

Durability — under normal conditions, the product will perform effectively as an external cladding with a service life of at least 30 years (see section 10).



The BBA has awarded this Certificate to the company named above for the product described herein. This product has been assessed by the BBA as being fit for its intended use provided it is installed, used and maintained as set out in this Certificate.

On behalf of the British Board of Agrément

Date of First issue: 13 November 2020

Hardy Giesler
Chief Executive Officer

Certificate amended on 24 September 2021 to revise sections 1.1, 1.3 and 4.7, and Figure 1.

The BBA is a UKAS accredited certification body – Number 113.

The schedule of the current scope of accreditation for product certification is available in pdf format via the UKAS link on the BBA website at www.bbacerts.co.uk

Readers MUST check the validity and latest issue number of this Agrément Certificate by either referring to the BBA website or contacting the BBA directly.

Any photographs are for illustrative purposes only, do not constitute advice and should not be relied upon.

British Board of Agrément

Bucknalls Lane
Watford
Herts WD25 9BA

©2020

tel: 01923 665300
clientservices@bbacerts.co.uk
www.bbacerts.co.uk

Regulations

In the opinion of the BBA, VitraDual, if installed, used and maintained in accordance with this Certificate, can satisfy or contribute to satisfying the relevant requirements of the following Building Regulations (the presence of a UK map indicates that the subject is related to the Building Regulations in the region or regions of the UK depicted):



The Building Regulations 2010 (England and Wales) (as amended)

Requirement: Comment:	A1	Loading The panel is acceptable for use as set out in section 6 of this Certificate.
Requirement: Comment:	B3(4)	Internal fire spread (Structure) The panel can contribute to satisfying this Requirement. See section 7.2 of this Certificate.
Requirement: Comment:	B4(1)	External fire spread The panel is unrestricted by this Requirement. See sections 7.1 and 7.4 of this Certificate.
Requirement: Comment:	C2(b)	Resistance to moisture The product, when used within a cladding system, is not watertight but will resist the passage of precipitation to the supporting structure. See section 8 of this Certificate.
Regulation: Comment:	7(1)	Materials and workmanship The panel is acceptable. See section 10 and the <i>Installation</i> part of this Certificate.
Regulation: Comment:	7(2)	Materials and workmanship The panel is unrestricted by this Regulation. See section 7.4 of this Certificate.



The Building (Scotland) Regulations 2004 (as amended)

Regulation: Comment:	8(1)(2)	Durability, workmanship and fitness of materials The panel can contribute to a construction satisfying this Regulation. See sections 9 and 10 and the <i>Installation</i> part of this Certificate.
Regulation: Standard: Comment:	9 1.1(a)(b)	Building standards applicable to construction Structure The panel is acceptable, with reference to clause 1.1.1 ⁽¹⁾⁽²⁾ of this Standard. See section 6 of this Certificate.
Standard: Comment:	2.4	Cavities The panel can contribute to satisfying this Standard with respect to clause 2.4.2 ⁽¹⁾⁽²⁾ . See section 7.2 of this Certificate.
Standard: Comment:	2.6	Spread to neighbouring buildings The panel is unrestricted by this Standard with respect to clauses 2.6.4 ⁽¹⁾⁽²⁾ , 2.6.5 ⁽¹⁾ and 2.6.6 ⁽²⁾ . See sections 7.1 and 7.4 of this Certificate.
Standard: Comment:	2.7	Spread on external walls The panel is unrestricted by this Standard with respect to clause 2.7.1 ⁽¹⁾⁽²⁾ . See sections 7.1 and 7.4 of this Certificate.
Standard: Comment:	3.10	Precipitation The panel will contribute to satisfying this Standard, with reference to clauses 3.10.1 ⁽¹⁾⁽²⁾ and 3.10.5 ⁽¹⁾⁽²⁾ . See section 8 of this Certificate.

Standard: Comment:	7.1(a)	Statement of sustainability The panel can contribute to meeting the relevant requirements of Regulation 9, Standards 1 to 6, and therefore will contribute to a construction meeting a bronze level of sustainability as defined in this Standard.
Regulation: Comment:	12	Building standards applicable to conversions Comments in relation to the product under Regulation 9, Standards 1 to 6 also apply to this Regulation, with reference to clause 0.12.1 ⁽¹⁾⁽²⁾ and Schedule 6 ⁽¹⁾⁽²⁾ .
		(1) Technical Handbook (Domestic). (2) Technical Handbook (Non-Domestic).



The Building Regulations (Northern Ireland) 2012 (as amended)

Regulation: Comment:	23(a)(i) (iii)(b)(i)	Fitness of materials and workmanship The panel is acceptable. See section 10 and the <i>Installation</i> part of this Certificate.
Regulation: Comment:	28(b)	Resistance to moisture and weather The panel can contribute to satisfying this Regulation. See section 8 of this Certificate.
Regulation: Comment:	30	Stability The panel is acceptable as set out in section 6 of this Certificate.
Regulation: Comment:	35(4)	Internal fire spread - Structure The panel is unrestricted by this Regulation. See section 7.2 of this Certificate.
Regulation: Comment:	36(a)	External fire spread The panel is unrestricted by this Regulation. See sections 7.1 and 7.4 of this Certificate.

Construction (Design and Management) Regulations 2015

Construction (Design and Management) Regulations (Northern Ireland) 2016

Information in this Certificate may assist the client, designer (including Principal Designer) and contractor (including Principal Contractor) to address their obligations under these Regulations.

See sections: 1 *Description* (1.2), 3 *Delivery and site handling* (3.4) and 9 *Maintenance* (9.3) of this Certificate.

Technical Specification

1 Description

1.1 VitraDual is a flat cladding panel made of aluminium sheet, grades EN AW-5754-H42/H111. The exposed face of the panel is coated with either 2 or 3 layers of polyvinylidene difluoride (PVDF) paint with polyurethane primer underneath; epoxy primer coating protects the unexposed face.

1.2 Full details and characteristics of VitraDual are shown in Table 1.

Table 1 Panel dimensions and characteristics

Characteristic (unit)	Value
Width (mm)	1250/1500
Length (mm)	2500/3200/4000
Thickness (mm)	3
Mass per unit area (kg·m ⁻²)	8.1
Coating – outward facing, PVDF (µm)	18-22 (2 layers) or 28-32 (3 layers)
Coating – outward facing, polyurethane primer (µm)	5-7
Coating – reverse facing, epoxy primer (µm)	7-12
Top coat colour	Any variation allowed

1.3 The panel is mechanically fastened to the Vitrafix Carrier Sub-Frame System⁽¹⁾ using stainless steel, plain or coloured Vitrafix Rivets, forming an open-jointed cladding system. The rivets dimensions are 4.8 x 16 mm with 16 mm head size and 4.8 mm body. The minimum edge distance is 16 - 50 mm both horizontally and vertically.

(1) Outside the scope of this Certificate.

1.4 Ancillary Items used with the products, but outside the scope of this Certificate, include:

- the Vitrafix Carrier Sub-Frame System (consisting of wall brackets at 500 mm maximum spacing and vertical L and T rails at 500 mm maximum spacing)
- screws attaching the vertical T-rail to the bracket
- fixings attaching Vitrafix sub-frame to the substrate wall (specification dependent on the strength of the substrate)
- substrate wall
- insulation within the cavity behind the cladding
- breather membrane
- cavity barriers
- protective cavity mesh.

2 Manufacture

2.1 Aluminium alloy coil, in the required dimensions, is cleaned by treating with appropriate chemicals. The coil is then coated with paint, and 2 ovens curing process follows. The panel can be cut to suit length and width if required.

2.2 As part of the assessment and ongoing surveillance of product quality, the BBA has:

- agreed with the manufacturer the quality control procedures and product testing to be undertaken
- assessed and agreed the quality control operated over batches of incoming materials
- monitored the production process and verified that it is in accordance with the documented process
- evaluated the process for management of nonconformities
- checked that equipment has been properly tested and calibrated
- undertaken to carry out the above measures on a regular basis through a surveillance process, to verify that the specifications and quality control operated by the manufacturer are being maintained.

3 Delivery and site handling

3.1 The panel is delivered to site in wooden pallets and wrapped in protective sheets. The pallets bear product details such as type, batch number, barcode, size, quantity, and description of the material, weight and colour.

3.2 The panel should be stored in a cool and dry area where temperature is relatively stable. Pallets of VitraDual should be stored horizontally with adequate support to prevent sagging. Stacked pallets should be identically sized and not more than four pallets high. To prevent surface damage when stacking VitraDual, there should be nothing between the panels.

3.3 Considerable care should be taken in the handling of the panel, it is sensitive to impact, particularly shocks from small, hard objects, which can dent it. A minimum of two people should be used when sliding large sheets to avoid scratching. Protective clothing should be worn and all Health and Safety measures observed.

3.4 The protective film on the panel should be removed within 45 days of installation to avoid glue residuals on the panel surface due to weathering. PVC tapes, polyurethane sealant or silicone sealant should not be applied onto the protective film. The plasticizer contained in these materials can penetrate the protective film and cause a gloss change in the coating. Spray paint or permanent marker should not be applied to the film as the colour may penetrate the film and affect the panel. The panel should be protected from any damage following removal of the protective film.

Assessment and Technical Investigations

The following is a summary of the assessment and technical investigations carried out on VitraDual.

Design Considerations

4 Use

4.1 VitraDual is satisfactory for use in an open-jointed, back-ventilated and drained cladding system on the external walls of new and existing buildings. VitraDual is for application onto timber- or metal-framed substrate walls.

4.2 The panel is installed with 10 mm horizontal and vertical joints between adjacent panels. The cavity behind the cladding should be at least 50 mm wide (see section 8).

4.3 It is important for designers, planners, contractors and/or installers to ensure that the installation of the panel is in accordance with the Certificate holder's instructions and the information given in this Certificate. All design aspects should be checked by a suitably qualified and experienced individual in accordance with the requirements of the relevant national Building Regulations and Standards. For advice on specific construction details, eg flue pipe penetrations, the Certificate holder should be consulted.

4.4 The substrate wall and the sub-frame to which the panel is fixed should be structurally sound. The substrate wall must satisfy the requirements of the relevant national Building Regulations and Standards regarding watertightness, and heat and sound transmission.

4.5 Ventilation and drainage must be provided behind the panel. All ventilation openings around the periphery of the system should be suitably protected with mesh to prevent the ingress of birds, vermin and insects.

4.6 To allow for longitudinal expansion, a minimum gap of 3 mm per metre length between adjacent sub-frame support rails should be provided. The panel must not be installed across this gap. To allow for expansion, the panel is installed on the sub-frame with one fixed fitted point in the middle of the panel and oversized holes for the edge fixings (see section 13.6).

4.7 As the panels are open-jointed, any insulation installed behind the cladding must be suitably fixed to the supporting wall to resist forces generated by wind actions and the insulation's self-weight. The insulation should be of a rigid or semi-rigid type (eg boards) and, where its performance could be diminished by moisture, a breather membrane should be provided over its outer face.

5 Practicability of installation

The product is suitable for installation by cladding contractors provided they have undergone suitable training. The Certificate holder can provide advice on installation if required.

6 Strength and stability

Wind loading



6.1 Wind actions should be calculated in accordance with BS EN 1991-1-4 : 2005 and its UK National Annex. Special consideration should be given to locations with high wind-load pressure coefficients, as additional fixings may be necessary. In accordance with BS EN 1990 : 2002 and its UK National Annex, it is recommended that a partial load factor of 1.5 is used to determine the design wind load to be resisted by a cladding system incorporating VitraDual.

6.2 The supporting substrate wall must have sufficient strength to resist independently the loads imparted directly by the cladding system and wind actions normally experienced in the UK, as well as any in plane force effects. The supporting sub-frame must have sufficient stiffness, such that its deformation does not affect the performance of the panel. The panel does not enhance the structural performance of the substrate wall.

6.3 The designer must ensure that:

- the design of the sub-frame and its fixings is in accordance with the relevant codes and Standards, such as to limit mid-span deflections to: span/200 and cantilever deflections to: span/150
- the panel is fixed to the sub-frame using the specified fixings. (see section 1.3)
- the number and arrangements of fixings provided adequate resistance to the design tensile and shear forces

6.4 For system arrangements other those stated in section 6.5, the wind load resistance should be taken as the lesser value between that obtained by considering the panels flexural rigidity and the resistance to pull-through of the panels in conjunction with specified fixings, also taking into consideration the aspects specified in section 6.3. These other arrangements are outside the scope of this Certificate.

Table 2 Design pull – through capacity of fixings (N)

Panel Thickness (mm)	Fixing centres (mm)	Fixings positions		
		middle	edge	corner
3	600	1046	872	107

(1) Tested in accordance with EAD 090062-00-0404 : 2018 Kits for external wall claddings mechanically fixed, annex i.1.

- fixings of the support brackets to the supporting wall have adequate tensile pull-out strength and corrosion resistance (outside the scope of this Certificate). An appropriate number of site-specific pull-out tests must be conducted on the substrate wall to determine the minimum pull-out resistance to failure of the fixings. The characteristic pull-out resistance should be determined in accordance with the guidance given in EOTA TR055, using 50% of the mean value of the five smallest measured values at the ultimate load.

6.5 Wind load tests were carried out on a wall comprising VitraDual, fixed to the Vitrafix Sub-Frame System using Vitrafix Rivets (4.8 x 16 mm), with vertical and horizontal spacing of 500 mm, and horizontal and vertical joints of 10 mm between panels. The Vitrafix Sub-Frame System consisted of L (50 x 50 x 2 mm) and T (100 x 45 x 2 mm) vertical rails supports spaced at 500 mm centres horizontally, attached to wall brackets vertically spaced at 500 mm max centres. The tested system achieved a design resistance⁽¹⁾ of 1.8 kN·m⁻².

(1) Derived by dividing the wind load test result by a partial factor of 2.0.

6.6 For system arrangements other those stated in section 6.5, the wind load resistance should be taken as the lesser value between that obtained by considering the panels flexural rigidity and the resistance to pull-through of the panels in conjunction with specified fixings, also taking into consideration the aspects specified in section 6.3. These other arrangements are outside the scope of this Certificate.

Impact



6.7 Hard and soft body impact tests were carried out on the same build up as detailed in section 6.5, and in accordance with CWCT Technical Note 76. Panels are suitable for use in all Use Categories as defined in EAD 090062-00-0404, an extract of which is reproduced in Table 2 of this Certificate.

Table 2 Definition of Use Categories (reproduced from EAD 090062-00-0404, Table G.2)

Use Category	Description
I	A zone readily accessible at ground level to the public and vulnerable to hard body impacts but not subjected to abnormally rough use
II	A zone liable to impacts from thrown or kicked objects, but in public locations where the height of the kit will limit the size of the impact; or at lower levels where access to the building is primarily to those with some incentive to exercise care
III	A zone not likely to be damaged by normal impacts caused by people or by thrown or kicked objects
IV	A zone out of reach from ground level

7 Behaviour in relation to fire



7.1 The panel has a reaction to fire classification of A1⁽¹⁾ in accordance with BS EN 13501-1 : 2018. This relates to the full thickness, colour range and mounting methods referred to in section 1 of this Certificate.

- (1) See report WF 431748 available from the Certificate holder. This classification is valid only for construction applications applied over any combustible wooden based substrate with a minimum density of 450 kg·m⁻³, a minimum thickness of 9 mm and a fire performance of D-s2, d0 or better, or construction applications over a rock-fibre mineral wool substrate with minimum thickness of 20 mm, minimum density of 30 kg·m⁻³ and an A1 reaction to fire classification or any appropriate A1 or A2-s1, d0 rated substrate listed in EN 13238 : 2010.

7.2 Cavity barriers should be provided in accordance with the requirements of the national building Regulations taking this into account.

7.3 Designers should refer to the relevant national Building Regulations and guidance for detailed conditions of use, particularly in respect of requirements for substrate fire performance, cavity barriers, service penetrations and combustibility limitations for other materials and components used in the overall wall construction, for example, thermal insulation.



7.4 The panel is classified as non-combustible and is not subject to any restriction on building height or proximity to boundaries (see also section 7.1 of this Certificate).

8 Air and water penetration



8.1 The panel is suitable for use in back-ventilated and drained cladding systems.

8.2 The substrate wall to which the cladding is fixed must be weathertight and reasonably airtight satisfying the requirements of the relevant national Building Regulations and Standards.

8.3 The amount of water entering the cavity by wind-driven rain will be minimal. Water collecting in the cavity owing to rain or condensation will be removed by drainage and ventilation.

8.4 To satisfy the NHBC requirements (see *NHBC Standards 2020*, Chapters 6.2, 6.9 and 6.10.18), the minimum clear, drained and ventilated cavity width between the back of the panel and front of the substrate wall (or insulation if installed within the cavity) must be 50 mm.

8.5 In addition, a minimum ventilation area of 5000 mm² per metre run of cladding at the building base point and at the roof edge, is required.

9 Maintenance and repair



9.1 To maintain the panel's appearance, a cleaning regime should be carried out using mineral spirits, organic cleaners or pH-neutral solvents. Cleaning frequencies are based on each project location. For more difficult chemical soiling, the Certificate holder's specialist advice must be sought.

9.2 Annual maintenance inspections must be carried out to ensure that such features as panels, flashings and seals are in place, and ancillary fixings are secure.

9.3 Damaged panels should be replaced as soon as practicable. Work carried out should follow the Certificate holder's instructions and all necessary Health and Safety regulations should be observed.

10 Durability



10.1 When incorporated in an overall wall cladding system, the panel should have a service life of at least 30 years if designed, installed and maintained in accordance with this Certificate.

10.2 The performance of the coating will depend upon the colour chosen, building location, façade aspect and immediate environment. Colour change will be generally small and uniform on any one elevation.

10.3 In a non-corrosive atmosphere, the panel can be expected to retain a good appearance for up to 20 years, and for 15 years in coastal or severe industrial regions.

10.4 In normal circumstances, the panel coating has adequate resistance to abrasion and scratching.

10.5 When tested for cracking in accordance with BS EN ISO 4628-4 : 2003, the panel coating was found to have adequate resistance.

10.6 When tested for rapid deformation caused by a falling weight (large-area indenter) in accordance with BS EN ISO 6272-1 : 2011, the panel coating was found to have satisfactory resistance to cracking or peeling.

11 Reuse and recyclability

The product is manufactured from aluminium which can be recycled.

Installation

12 General

12.1 VitraDual must be installed in accordance with the Certificate holder's recommendations, the requirements of this Certificate and the specifications laid down by the design engineer.

12.2 Installers must be trained and approved by the Certificate holder who can provide technical assistance at the design stage and at the start of the installation.

12.3 Installation of the panel should be carried out between temperatures of 5 and 25°C. Extremes of temperature must be avoided.

12.4 The panel must be mounted to allow for thermal expansion movement. When the panel is secured, allowance for expansion must also be made by the appropriate use of clearance holes at fixings.

12.5 The panel can be worked by conventional techniques in accordance with the Certificate holder's instructions. These include sawing and cutting, drilling and riveting. It is essential that the correct tools, in good condition, are used to prevent any damage to the coating, and that swarf is removed.

12.6 The panel may be fabricated for installation in either the vertical or horizontal plane. The panel may be predrilled in the factory or on site.

13 Procedure

13.1 Based on a preliminary survey of the wall and the architectural/structural design, a grid layout for the sub-frame (wall brackets and vertical rails) is prepared.

13.2 Wall brackets are fixed to the substrate using appropriate fixings. Vertical spacing between wall brackets should be as specified by the Certificate holder.

13.3 Where required, a rigid or semi-rigid insulation, protected by a suitable breather membrane (both outside the scope of this Certificate), can be installed on the substrate wall. The thickness of the insulation should be such as to ensure a minimum ventilation cavity width at the back of the panel is maintained (see section 8.4).

13.4 Vertical support rails are fixed to the brackets with provision for an expansion gap between adjacent vertical rails (see section 4.6).

13.5 The panel is fixed to vertical rails ensuring minimum vertical and horizontal gaps between panels are maintained (see section 8.4). To allow for thermal expansion, the correct specified pre-drilled fixing holes are required for both the panel and support rail. Fixing heads must have sufficient overlap onto the panel and must be concentrically positioned ensuring that the panel is not fixed too tightly, and therefore prevent the face of panel to move and pull causing distortion to the surface.

13.6 Typical installation details are shown in Figure 1.

Figure 1 Typical installation details

(A) Panel fixing arrangement

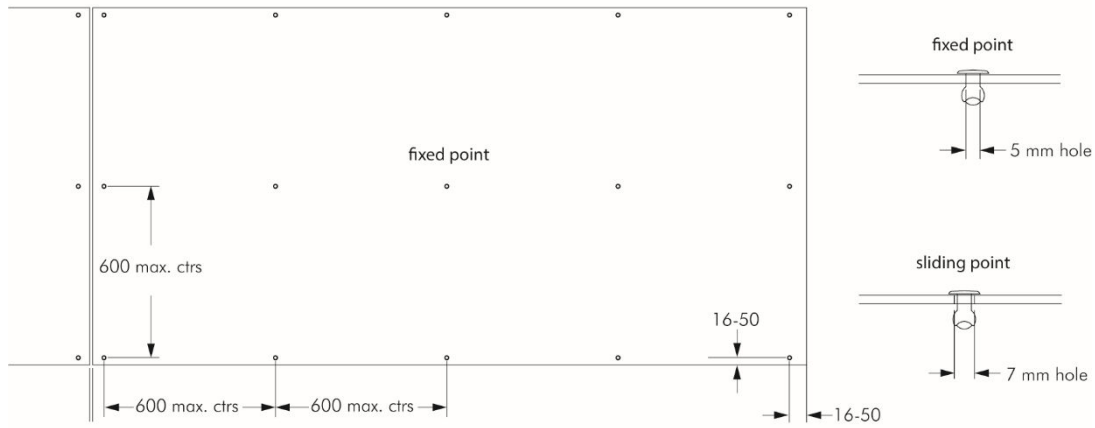

(B) Vitradual rivet fix detail showing typical joint

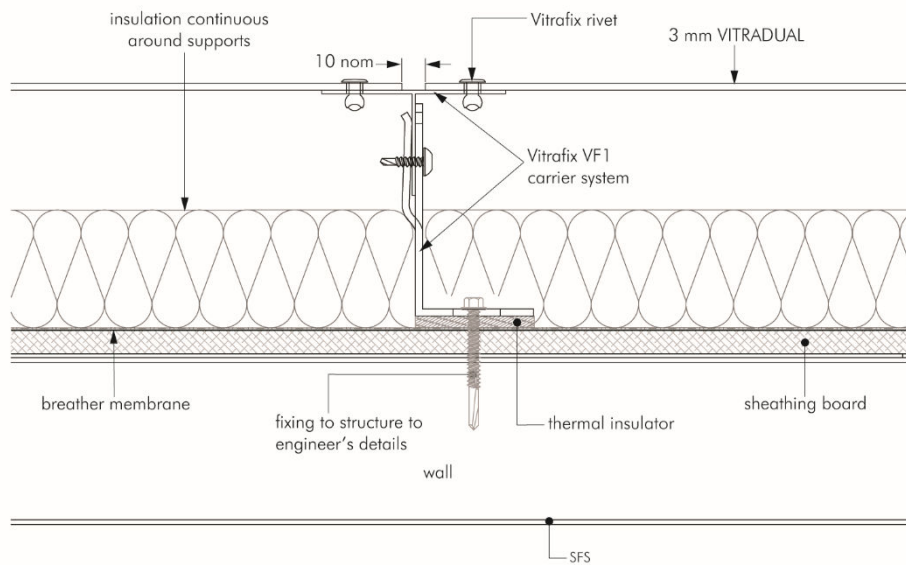

(C) Vitradual rivet fix detail showing horizontal joint

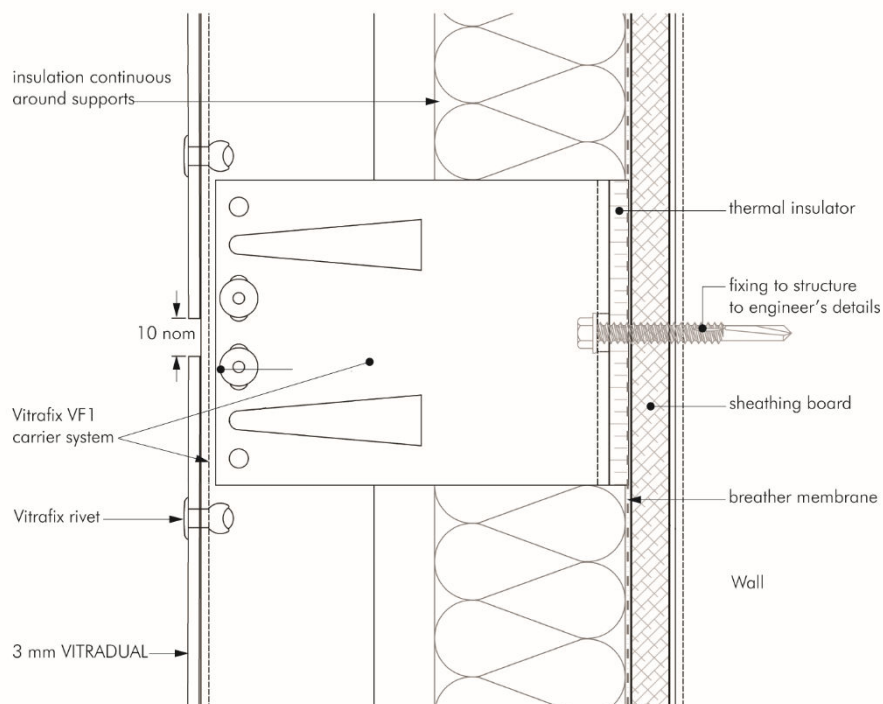
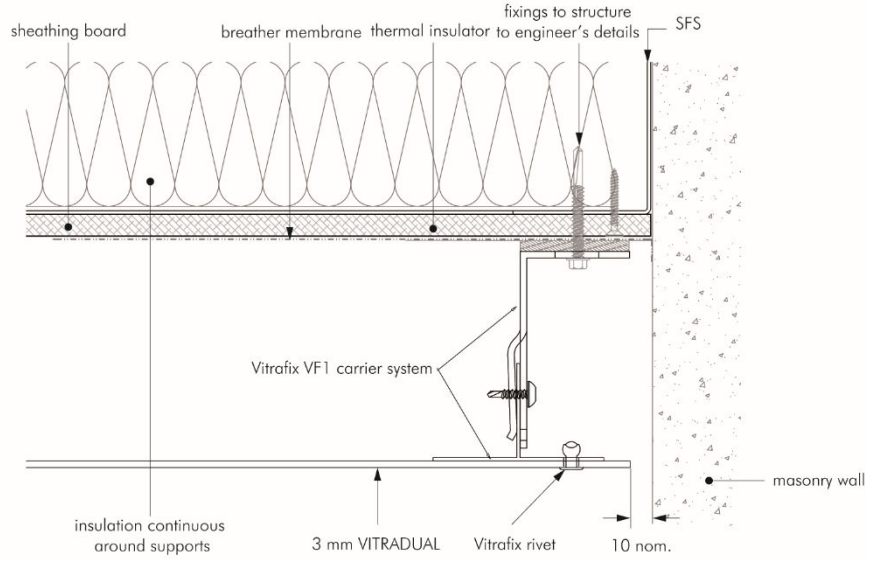
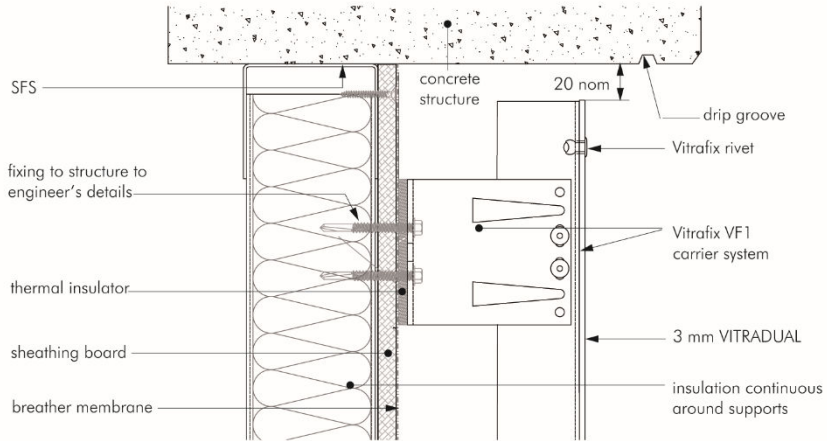

Figure 1 Typical installation details (continued)

(D) Vitradual rivet fix detail showing panel at masonry wall



(E) Vitradual rivet fix detail showing slab junction head



(F) Vitradual rivet fix detail showing slab base junction

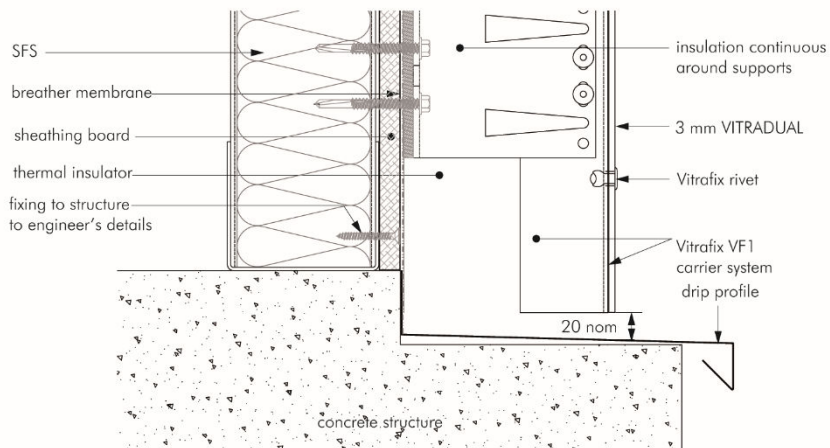
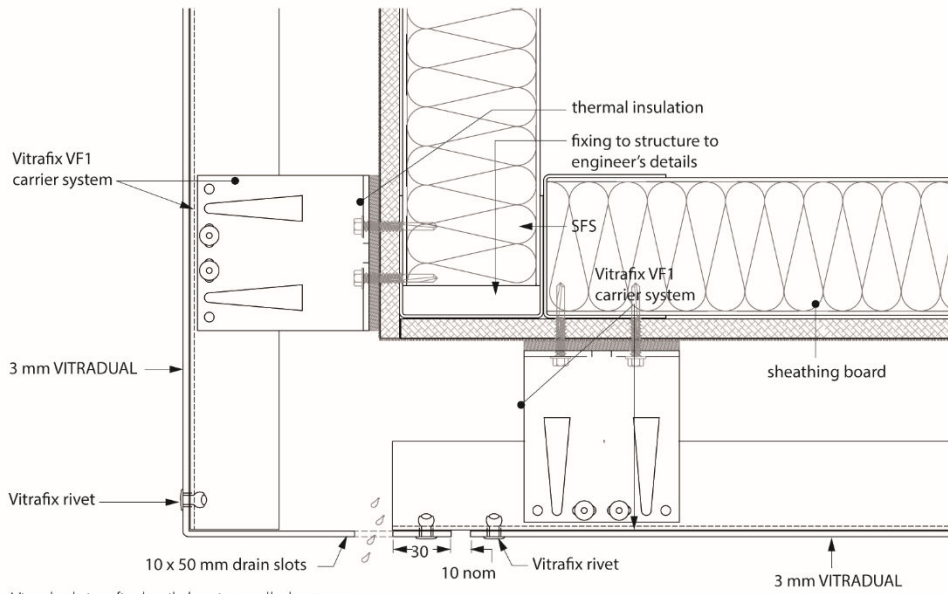
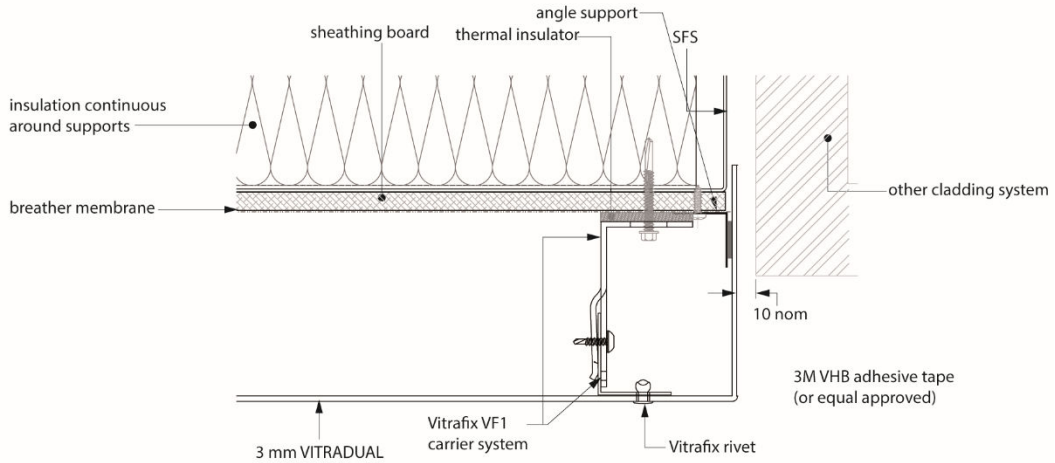

Figure 1 Typical installation details (continued)

(G) Vitradual rivet fix detail showing soffit junction



(H) Vitradual rivet fix detail showing wall abutment



(I) Vitradual rivet fix detail showing external corner

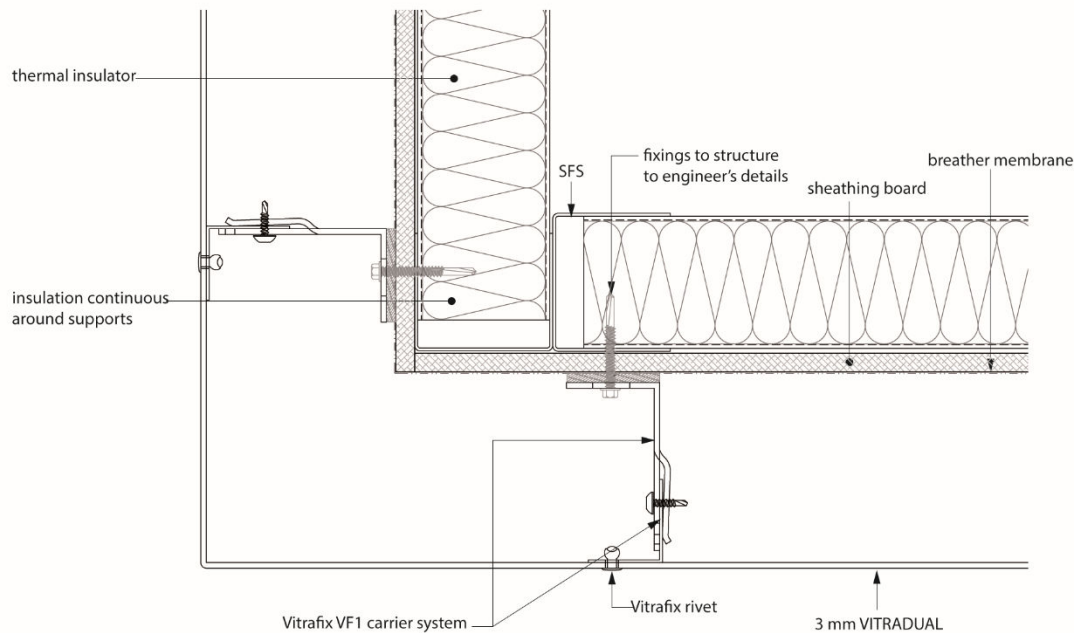
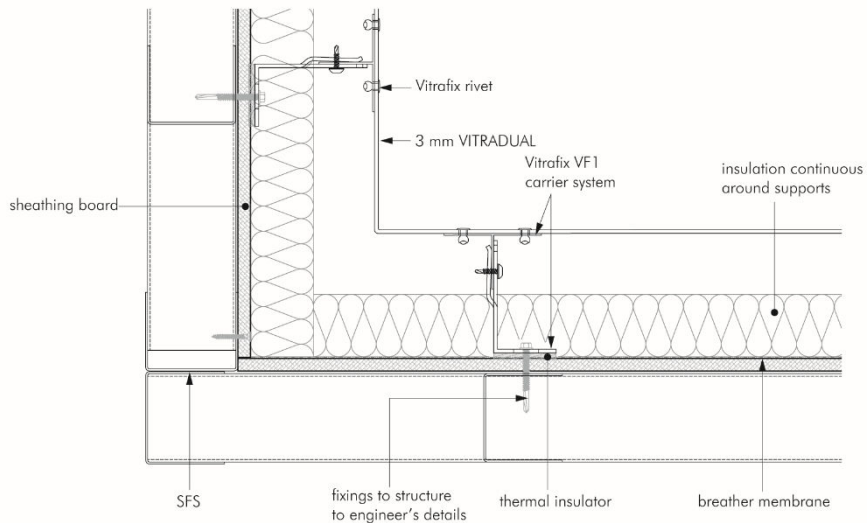
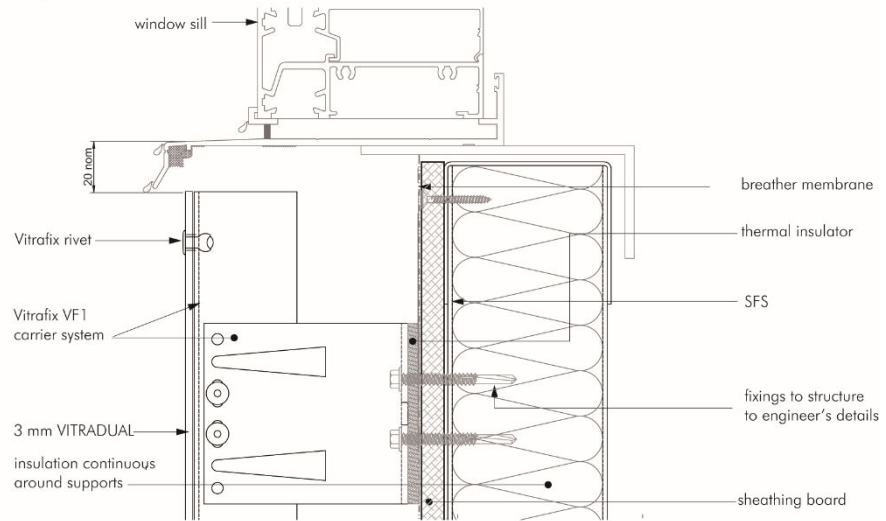

Figure 1 Typical installation details (continued)

(J) Vitradual rivet fix detail showing internal corner



(K) Vitradual rivet fix detail showing window sill



(L) Vitradual rivet fix detail showing window head

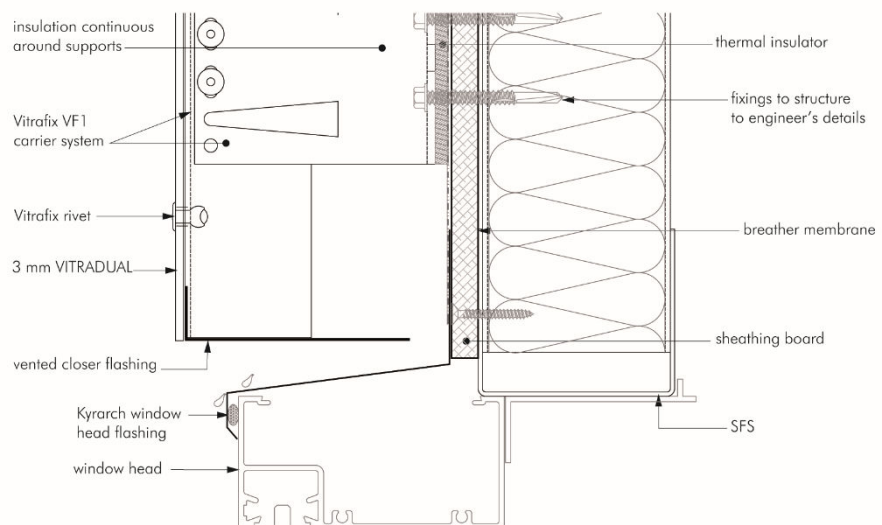
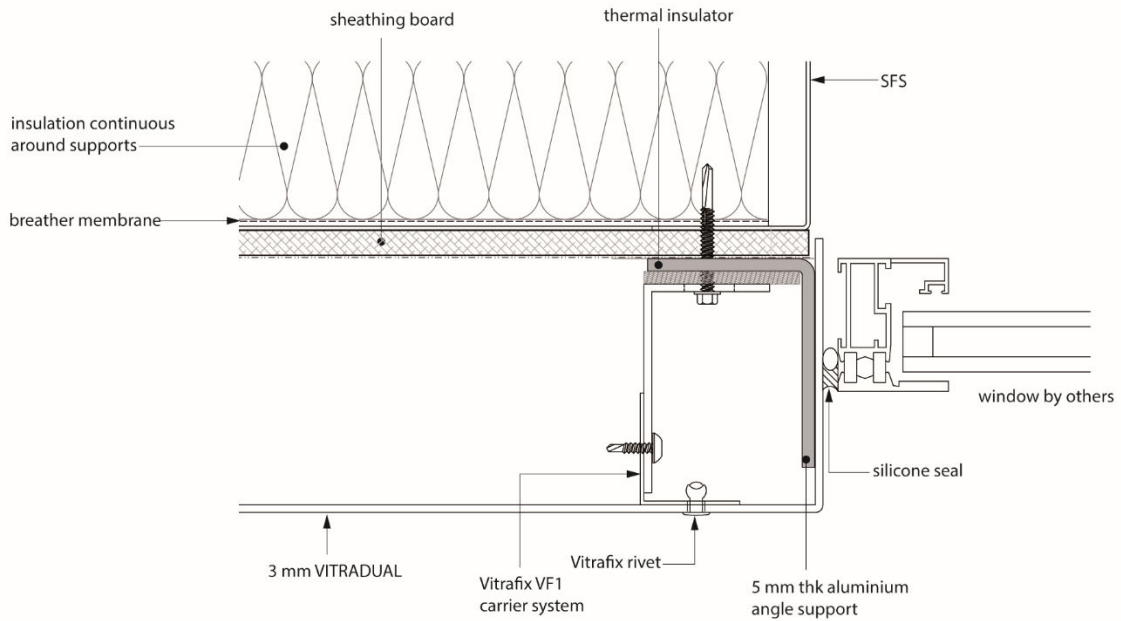
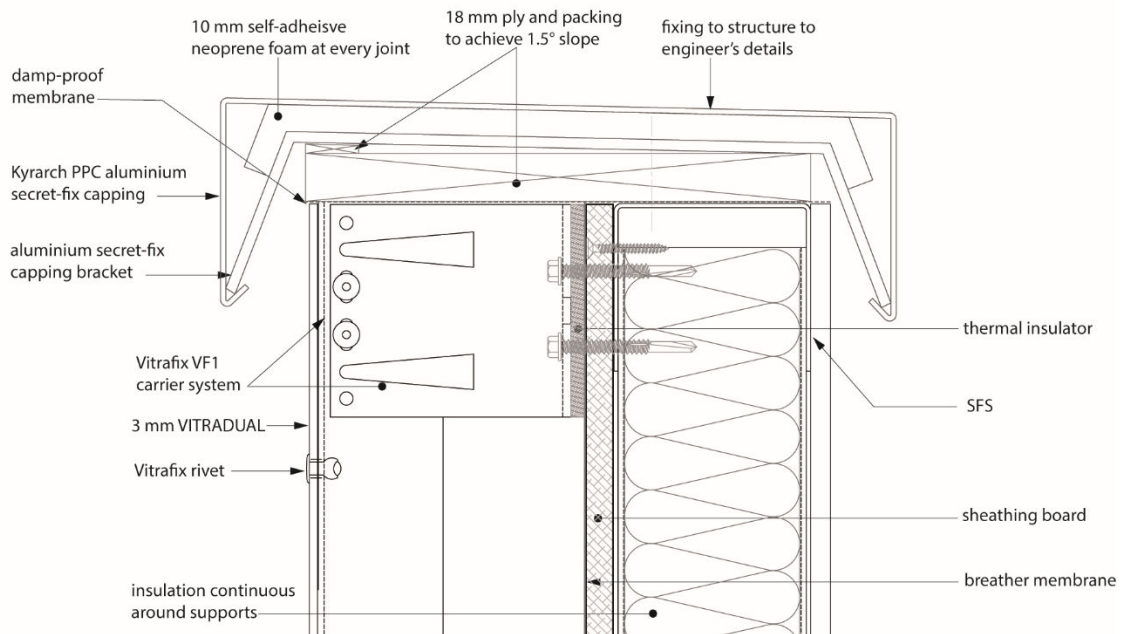

Figure 1 Typical installation details (continued)

(M) Vitradual rivet fix detail showing window jamb



(N) Vitradual rivet fix detail showing parapet capping 1



14 Tests

14.1 Based on independent test data, an assessment was made of:

- resistance to wind loading
- resistance to impact
- material characteristics
- durability
- behaviour in relation to fire.

14.2 The manufacturing process was evaluated, including the methods adopted for quality control, and details were obtained of the quality and composition of the materials used.

Bibliography

BS EN 1990 : 2002 + A1 : 2005 *Eurocode — Basis of structural design*

NA to BS EN 1990 : 2002 + A1 : 2005 *UK National Annex to Eurocode — Basis of structural design*

BS EN 1991-1-4 : 2005 + A1 : 2010 *Eurocode 1 — Actions on structures — General actions — Wind actions*

NA to BS EN 1991-1-4 : 2005 + A1 : 2010 *UK National Annex to Eurocode 1 — Actions on structures — General actions — Wind actions*

BS EN 13501-1 : 2018 *Fire classification of construction products and building elements — Classification using test data from reaction to fire tests*

BS EN 13238 : 2010 *Reaction to fire tests for building products. Conditioning procedures and general rules for selection of substrates.*

BS EN ISO 4628-4 : 2016 – *TC Tracked Changes. Paints and varnishes. Evaluation of degradation of coatings. Designation of quantity and size of defects, and of intensity of uniform changes in appearance. Assessment of degree of cracking.*

BS EN ISO 6272-1 : 2011 *Paints and varnishes. Rapid-deformation (impact resistance) tests. Falling-weight test, large-area indenter.*

ETAG 034 : 2012 *Guideline for European Technical Approval of Kits for External Wall Claddings*

EAD 090062-00-0404 *Kits for external wall claddings mechanically fixed*

EOTA TR055 : 2016 *Design of fastenings based on EAD 330232-00-0601*

15 Conditions

15.1 This Certificate:

- relates only to the product/system that is named and described on the front page
- is issued only to the company, firm, organisation or person named on the front page – no other company, firm, organisation or person may hold or claim that this Certificate has been issued to them
- is valid only within the UK
- has to be read, considered and used as a whole document – it may be misleading and will be incomplete to be selective
- is copyright of the BBA
- is subject to English Law.

15.2 Publications, documents, specifications, legislation, regulations, standards and the like referenced in this Certificate are those that were current and/or deemed relevant by the BBA at the date of issue or reissue of this Certificate.

15.3 This Certificate will remain valid for an unlimited period provided that the product/system and its manufacture and/or fabrication, including all related and relevant parts and processes thereof:

- are maintained at or above the levels which have been assessed and found to be satisfactory by the BBA
- continue to be checked as and when deemed appropriate by the BBA under arrangements that it will determine
- are reviewed by the BBA as and when it considers appropriate.

15.4 The BBA has used due skill, care and diligence in preparing this Certificate, but no warranty is provided.

15.5 In issuing this Certificate the BBA is not responsible and is excluded from any liability to any company, firm, organisation or person, for any matters arising directly or indirectly from:

- the presence or absence of any patent, intellectual property or similar rights subsisting in the product/system or any other product/system
- the right of the Certificate holder to manufacture, supply, install, maintain or market the product/system
- actual installations of the product/system, including their nature, design, methods, performance, workmanship and maintenance
- any works and constructions in which the product/system is installed, including their nature, design, methods, performance, workmanship and maintenance
- any loss or damage, including personal injury, howsoever caused by the product/system, including its manufacture, supply, installation, use, maintenance and removal
- any claims by the manufacturer relating to CE marking.

15.6 Any information relating to the manufacture, supply, installation, use, maintenance and removal of this product/system which is contained or referred to in this Certificate is the minimum required to be met when the product/system is manufactured, supplied, installed, used, maintained and removed. It does not purport in any way to restate the requirements of the Health and Safety at Work etc. Act 1974, or of any other statutory, common law or other duty which may exist at the date of issue or reissue of this Certificate; nor is conformity with such information to be taken as satisfying the requirements of the 1974 Act or of any statutory, common law or other duty of care.